

Please ensure your vehicle is clean from dust and dirt before you put on your car cover to make sure dust particles do not scratch the paint.

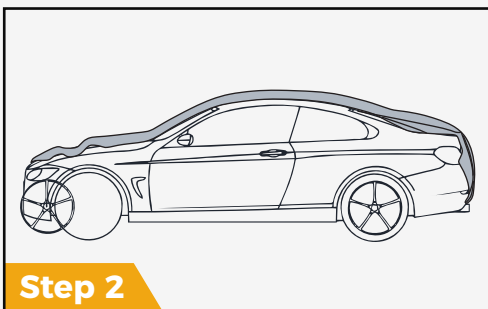

Carefully remove your cover from the carrying case and place it on the top of your vehicle with the tag "front" of the cover facing the front of your vehicle, and ensure the cover doesn't touch the ground. You will find a "Front" tag sewn on the inside of the cover seam to easily identify the front side of the cover.

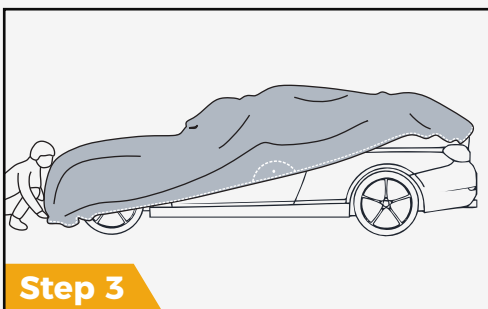

Attach the elasticised front of the cover to the front bumper of your vehicle. From there, roll out and pull the cover over the vehicle's top all the way to the back and attach the elasticised ham to the rear bumper. Fasten the side buckles to fix the cover in place.

Note: In case you have an antenna, make sure you remove it before placing the cover. If it's a retractable antenna, retract it prior to placing the cover to avoid fitting issues.

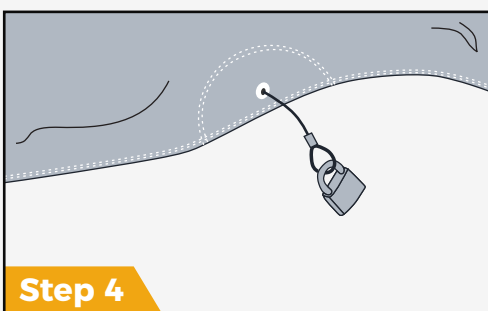

Use the cable lock system underneath your vehicle to secure the cover and ensure that it does not move around or get blown away.

To use the cable and lock, simply loop the cable through itself, feed it through the grommet, create another loop, and then attach the lock.

*The cable+lock system comes either included or as an upgrade for some of the products.

Here is a video demonstration:



Follow installation instructions carefully to avoid your cover getting dirty, scratched or ripped. Store the product in a dry place.
WARNING: Keep plastic bags away from children and pets. Use as intended. Do not use it as a toy.

Materials needed:

- All-purpose cleaner or mild detergent
- Water - warm or cold (avoid using hot water)
- Bucket
- Hose
- Sponge
- A place to hang it dry

Instructions:

- Put the cover on your car. Stretch it tight to minimise wrinkles or folds.
- Fill a bucket with water and mild detergent.
- Spray the cover with a hose to loosen any debris or residue (e.g. dirt, bird droppings, etc.).
- Soak the sponge in the detergent solution and gently scrub the cover.
- Rinse thoroughly with the hose two to three times to remove all traces of suds.
- If you wish to clean the inside of the cover you can place it on your vehicle inside out.
- Repeat the previous steps.
- Remove the cover and hang to air dry.

What NOT to do with your Car Cover

- Do not cover a hot tail pipe.
- Do not cover a vehicle with the convertible top down, windows or sunroof open, or T-tops removed
- Do not cover the vehicle directly after waxing.
- Do not cover a wet vehicle. In the event of rain, wait until the car dries completely before placing the cover on the vehicle.
- Repainted vehicles should NOT be immediately covered. Please check with your painter or auto body shop for their recommended cure time. Premature use of a cover in this situation could result in damage to repainted surfaces or lacquer paint.
- Do not attempt to pull or move the car cover if it is frozen.
Rarely, a thin layer of ice will form between your vehicle and the car cover. Fortunately, there is a quick and simple solution! Suppose it is necessary to remove the cover. In that case, we recommend pouring warm water over the vehicle and slowly removing the cover, inspecting the surfaces of both the car cover and the vehicle during the removal process. Stop immediately if you encounter resistance – the ice has not been melted completely, and you must pour more warm water over the vehicle.

Warranty Summary

In the unlikely event that you need to use the provided warranty, here are the steps to follow:

- Please contact our Customer Support;
- Make sure to provide pictures/videos to our Customer Support, showcasing the problem or issue you are experiencing with your car cover;
- After careful consideration, our Customer Support specialist will contact you to talk about proceeding to the solution: which can either be repair or replacement of your car cover.

The following cases will not be considered eligible for the warranty:

- In case there is any physical damage, other than you have initially indicated, to the car cover you sent back to us in the package;
- In case the customer doesn't provide any proof that the cover doesn't fit their car
- In case the customer doesn't provide any proof of purchase, i.e., email, invoice.